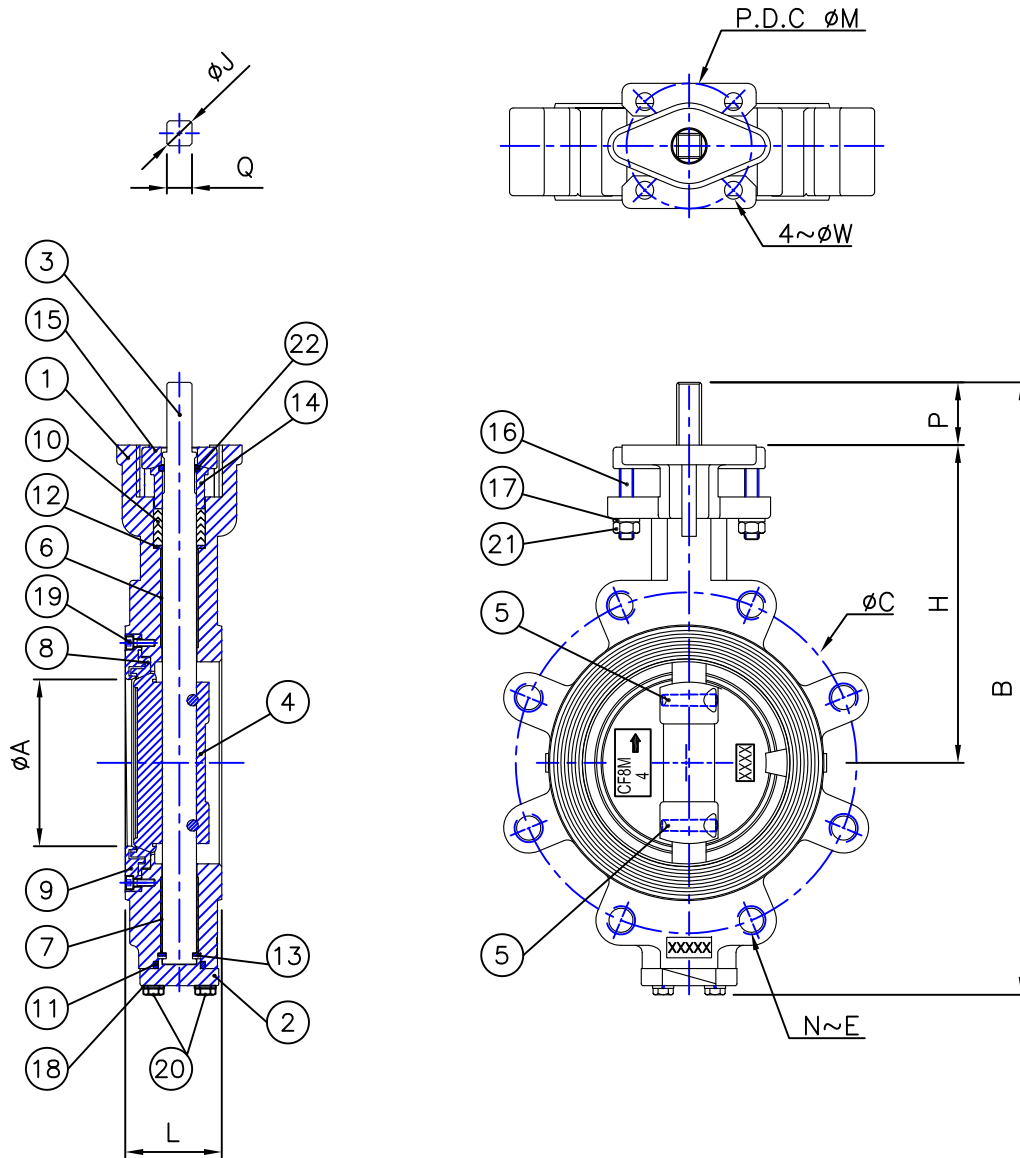

Fig No:

F2-BL15

### MATERIAL LIST

NO.	PART NAME	MATERIAL		Q'TY
		STAINLESS STEEL	CARBON STEEL	
1	BODY	A351-CF8M	A216-WCB	1
2	CAP	A351-CF8M	A216-WCB	1
3	STEM	A564 17-4PH		1
4	DISC	A351-CF8M		1
5	DISC PIN	SS304		2
6	STEM BEARING(1)	SS304 + Graphite + Teflon		1
7	STEM BEARING(2)	SS304 + Graphite + Teflon		1
8	SEAT	TFM		1
9	SEAT SUPPORT	A351-CF8M	A216-WCB	1
10	PACKING(1)	PTFE		1SET
11	PACKING(2)	PTFE		1
12	WASHER(1)	SS304		1
13	WASHER(2)	SS316		1
14	GLAND	SS316		1
15	GLAND FLANGE	A351-CF8M		1
16	GLAND BOLT	SS304		2
17	SPRING WASHER(1)	SS304		2
18	SPRING WASHER(2)	SS304		4
19	SCREW(1)	SS304		8~12
20	SCREW(2)	SS304		4
21	NUT	SS304		2
22	WASHER(3)	SS316		1



### DIMENSIONS

unit:mm

SIZE	A	C	N	E	L	B	H	P	Q	J	M	W
3"	72.1	152.5	4	5/8-11UNC	50	312.7	160.3	35	11	14	70	10
4"	93.2	190.5	8	5/8-11UNC	54	342.2	212.6	35	14	18	70	10
6"	138.1	241.5	8	3/4-10UNC	57.6	421.9	249	35	17	22	70	10